

MDBOX018

Video delle istruzioni:
Product Instructions:

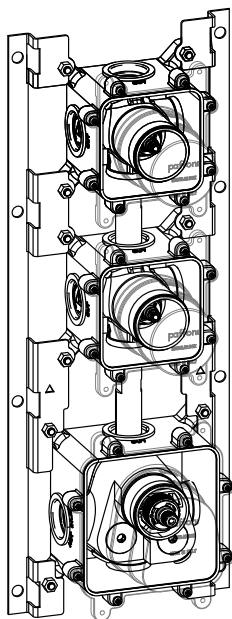

<https://www.paffoni.it/info/modular-box?q=mdbox018>



INSTALLAZIONE VERTICALE
VERTICAL INSTALLATION

INSTALLAZIONE ORIZZONTALE
HORIZONTAL INSTALLATION

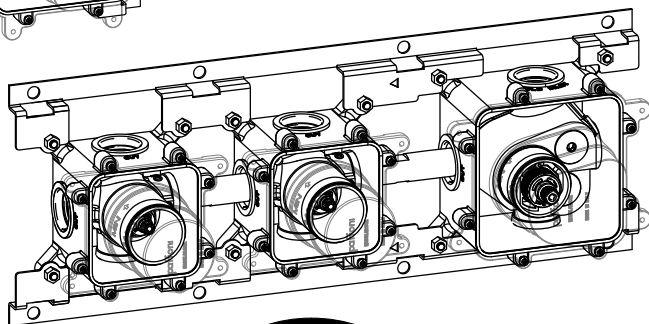

INSTALLAZIONE VERTICALE VERTICAL INSTALLATION

1 Montaggio Assembly

Prima di chiudere
il muro eseguire lo
spurgo e la prova di
pressione

Before concluding the
wall finishing operation
make purge and
pressure test



EN1717

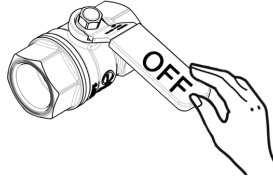

$65 \pm 5^\circ\text{C}$



$15 \pm 5^\circ\text{C}$



MIN - MAX



OK

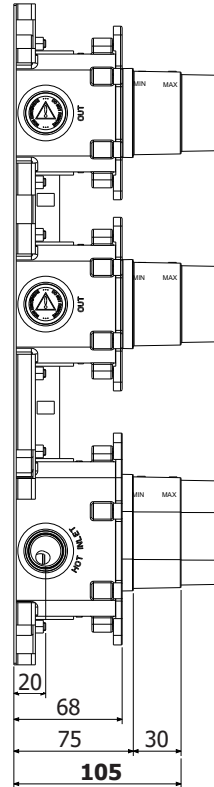
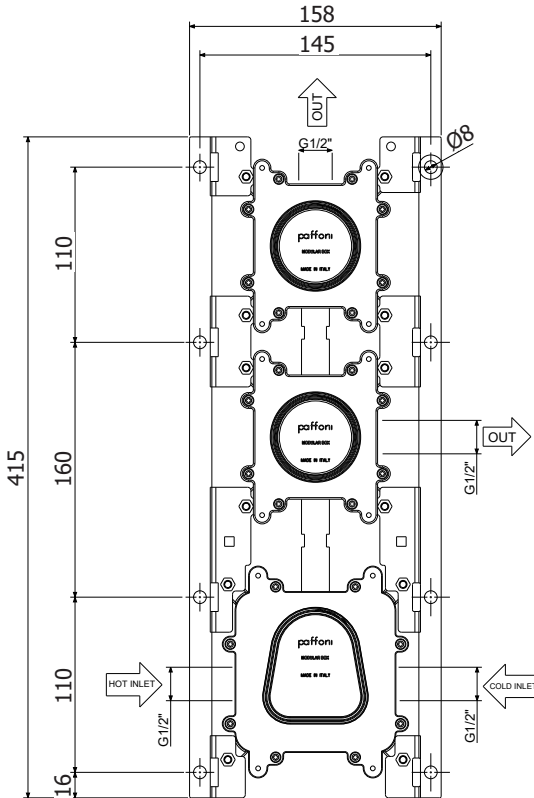

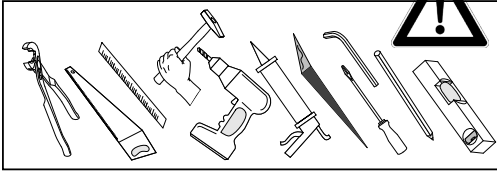

INSTALLAZIONE VERTICALE CON GRUPPO TERMOSTATICO SOLO SOTTO
 VERTICAL INSTALLATION WITH THERMOSTATIC ONLY IN DOWN SIDE

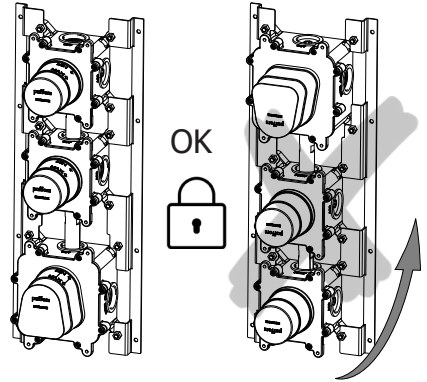
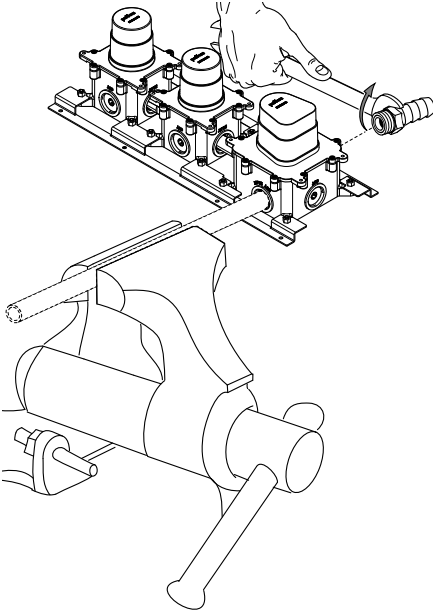

Non rimuovere i tappi
 Don't remove plugs

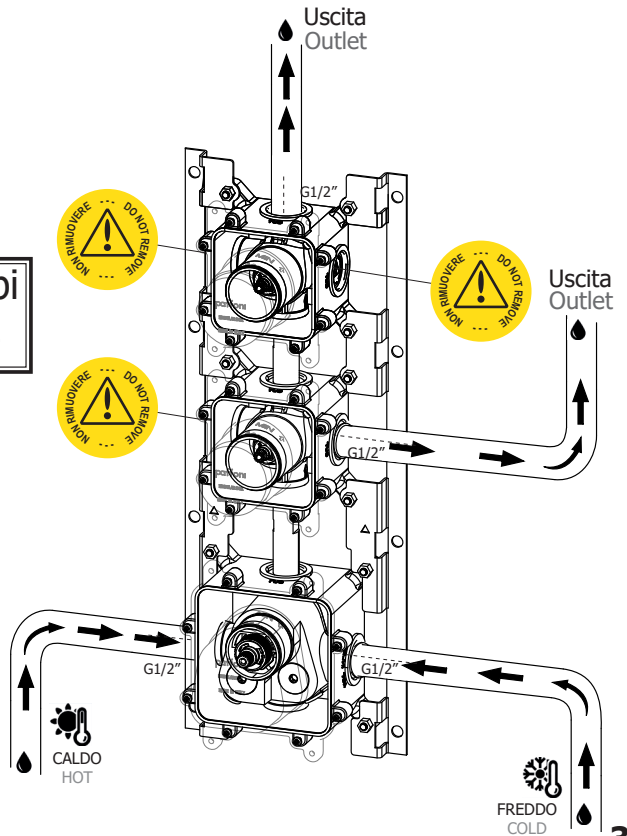

Ingombro dello spessore del rivestimento

Thickness size of the coating

Tenere ferma la dima per foratura e allinearla con una livella a bolla d'aria.

Hold up the drilling template and level it with a spirit level.

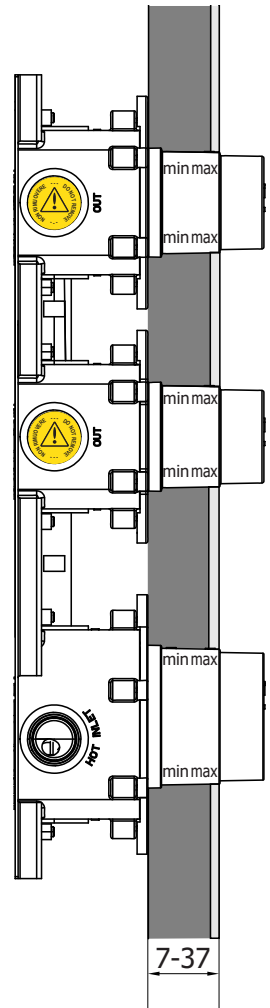
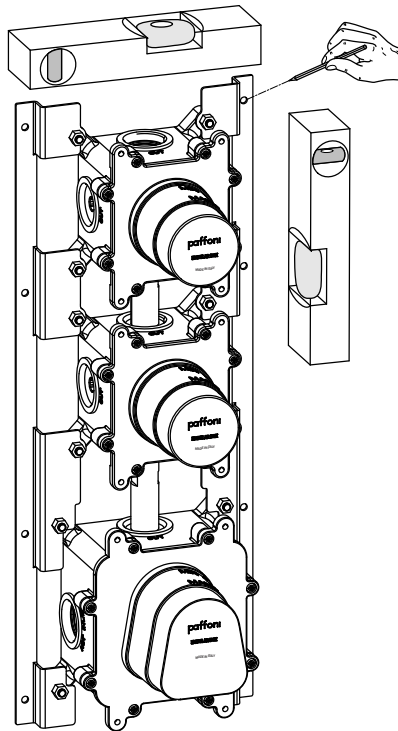
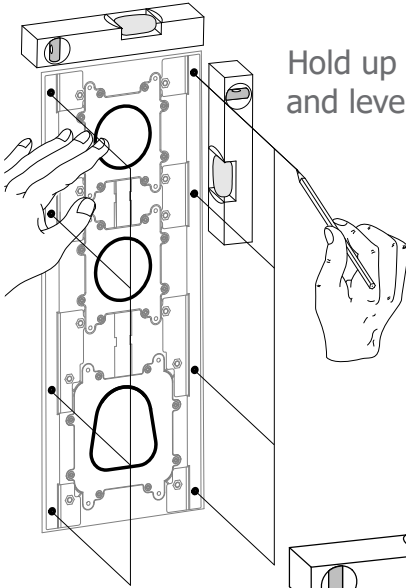

Tipologie di installazione

Types of installations

1

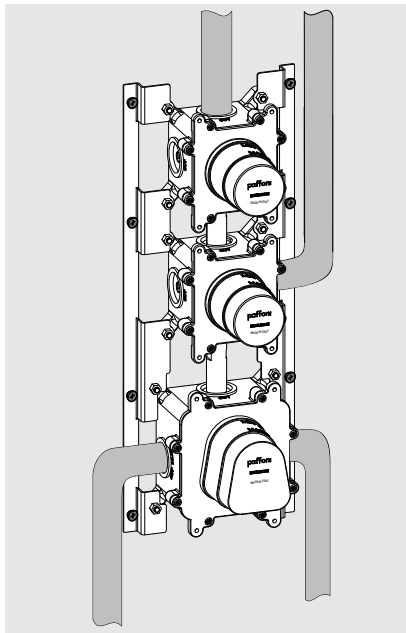

Prima di completare con i rivestimenti eseguire i **test pressione e spurgo**. p.8
Before complete coating make **purge and pressure test**. p.7

Fissaggio posteriore in appoggio sul muro
Back fixing resting on the wall

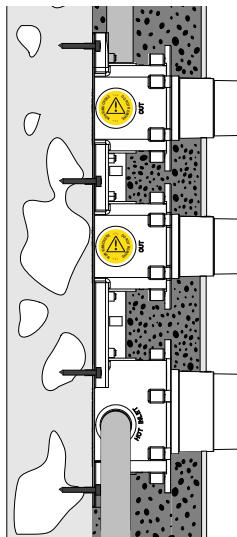

2

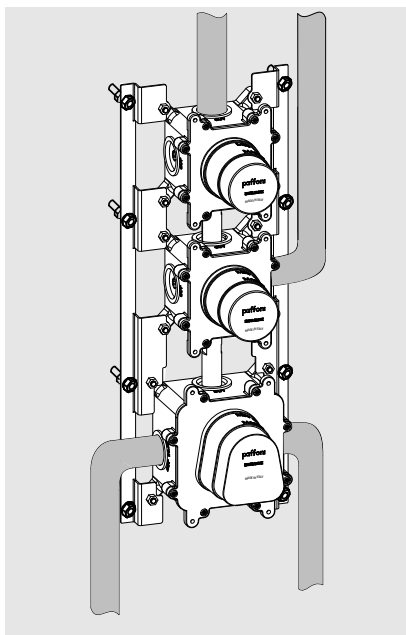

Prima di completare con i rivestimenti eseguire i **test pressione e spurgo**. p.8
Before complete coating make **purge and pressure test**. p.7

Fissaggio posteriore sospeso su tasselli
Back fixing hanging on dowels

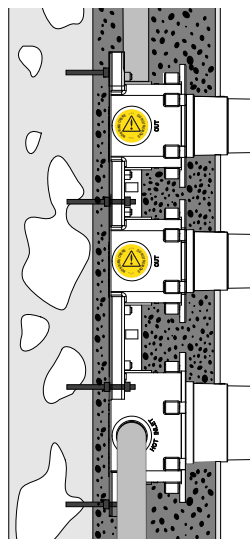

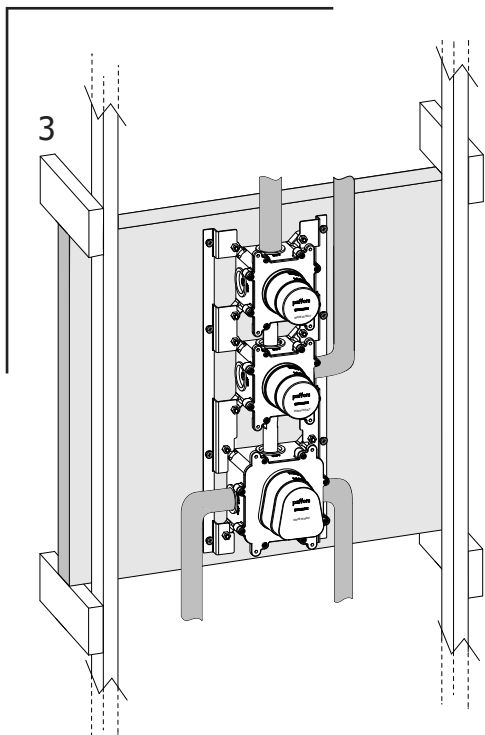

Fissaggio posteriore in
intercapedine

Back fixing in interspace

Prima di
completare con
i rivestimenti
eseguire i
**test pressio-
ne e spurgo.**
p.8
Before com-
plete coating
make **purge
and pressure
test.** p.7

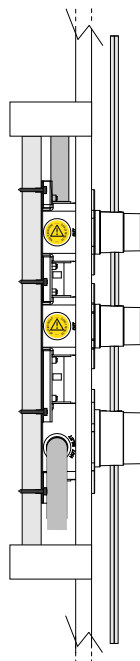
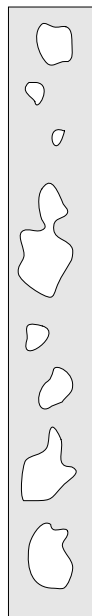

Spurgo
Purge

a

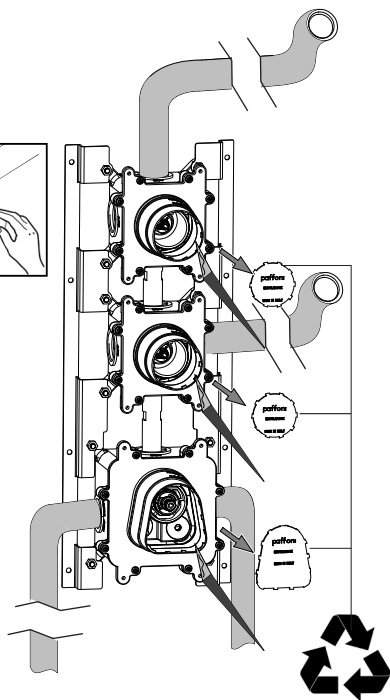
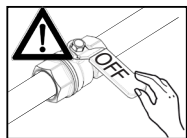

b

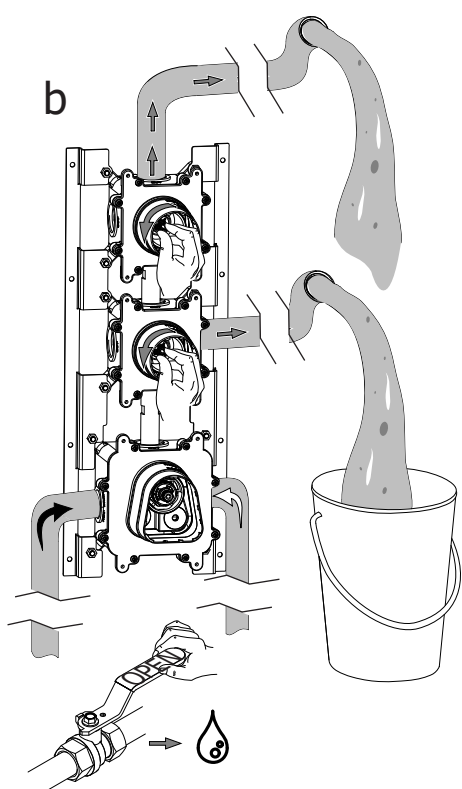

Test perdite e di pressione
Leak and pressure test

a

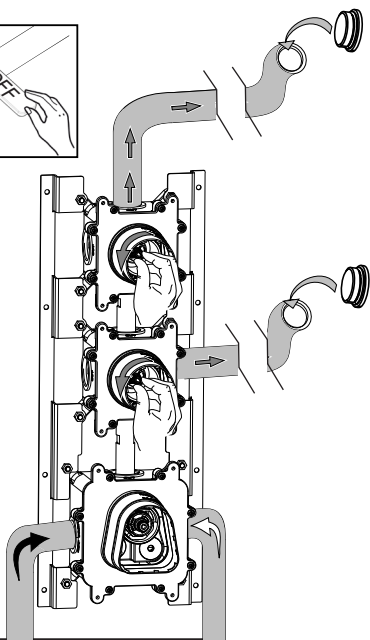
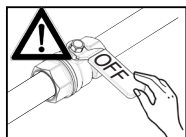

b

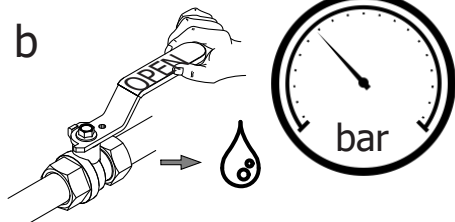

c



a

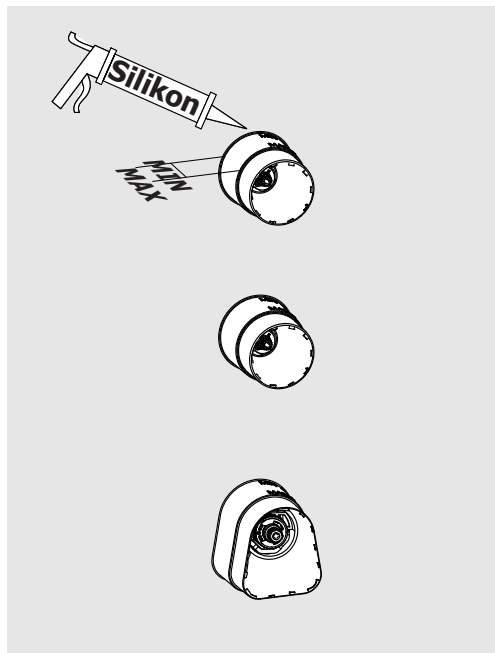

b

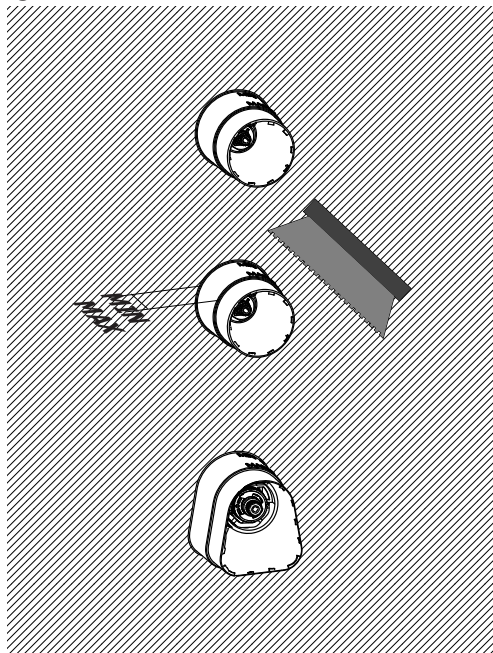

c

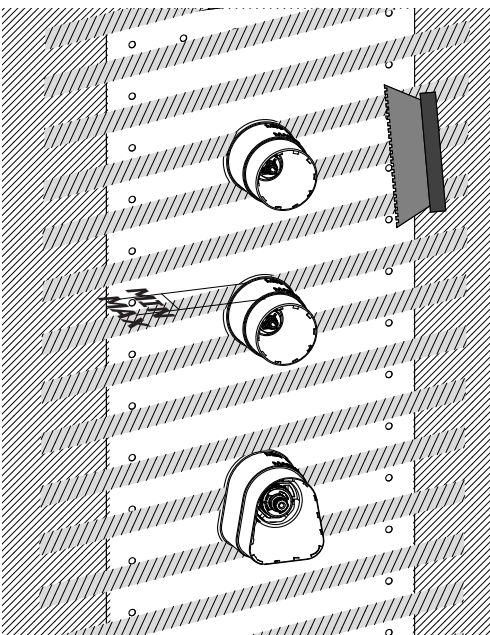

d

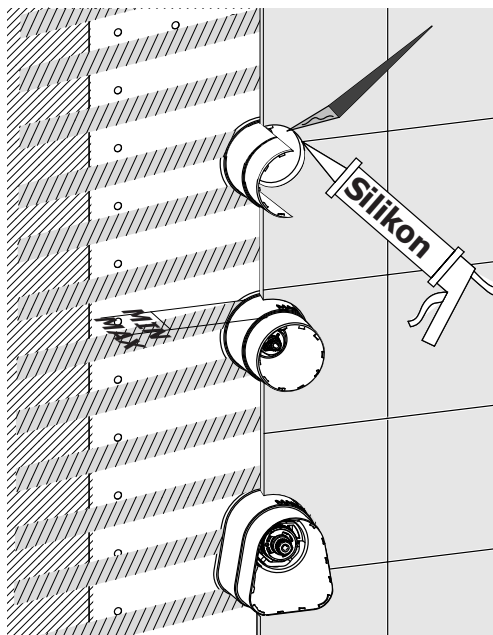

INSTALLAZIONE ORIZZONTALE HORIZONTAL INSTALLATION

1 Montaggio Assembly

Prima di chiudere il muro eseguire lo spurgo e la prova di pressione
Before concluding the wall finishing operation make purge and pressure test



EN1717

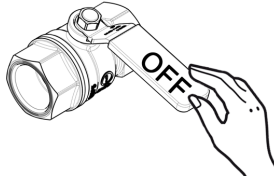

$65 \pm 5^{\circ}\text{C}$



$15 \pm 5^{\circ}\text{C}$



MIN - MAX



OK

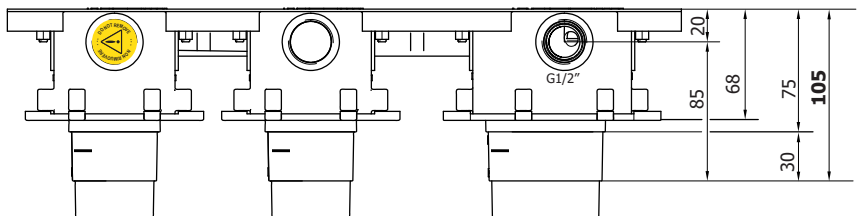
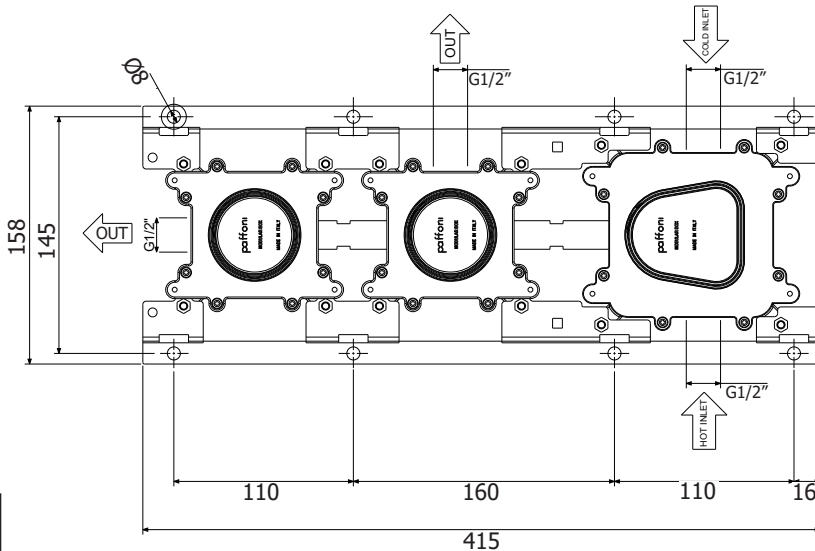

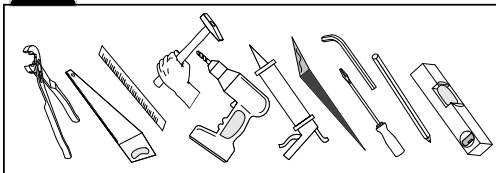

INSTALLAZIONE ORIZZONTALE CON
GRUPPO TERMOSTATICO SOLO A DESTRA
HORIZONTAL INSTALLATION WITH
THERMOSTATIC ONLY IN RIGHT SIDE

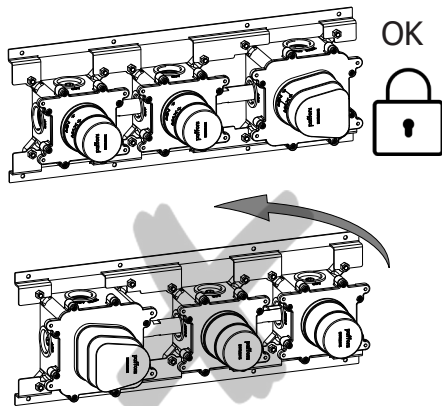
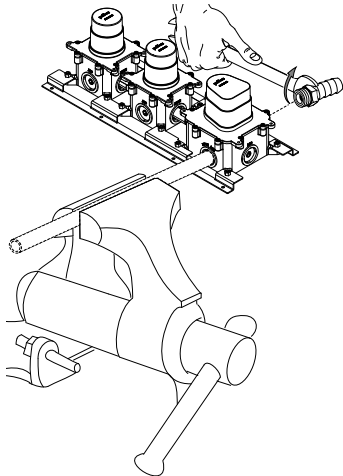

Non rimuovere i tappi
Don't remove plugs

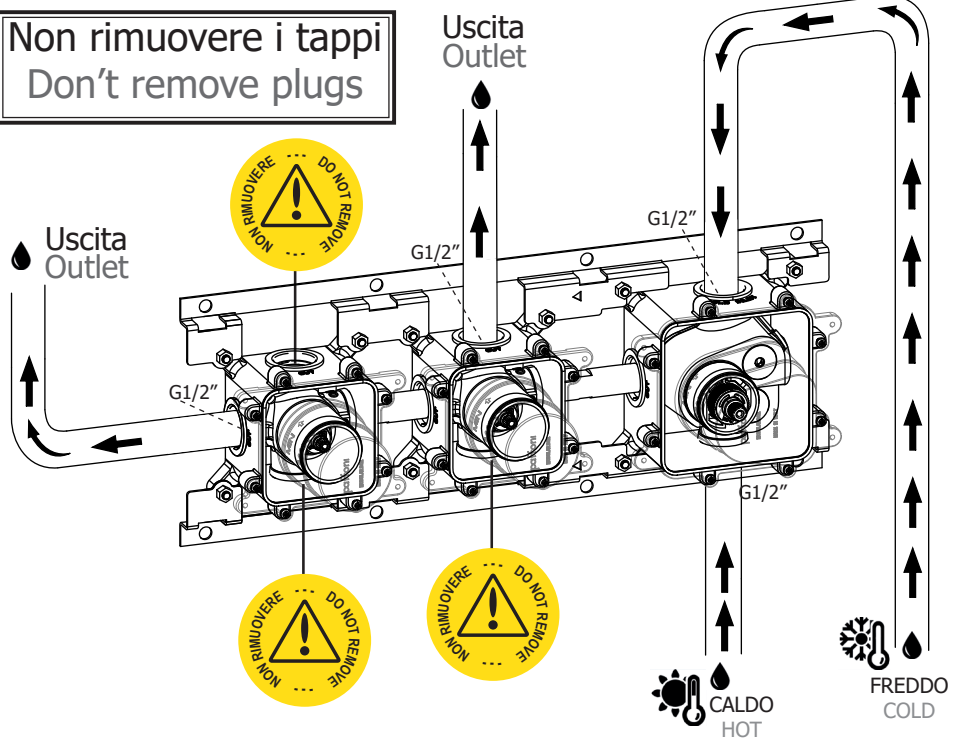

Ingombro dello spessore del rivestimento

Thickness size of the coating

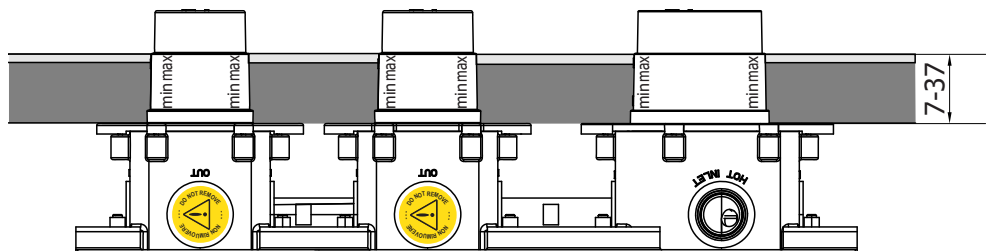

Tenere ferma la dima per foratura e allinearla con una livella a bolla d'aria.
Hold up the drilling template and level it with a spirit level

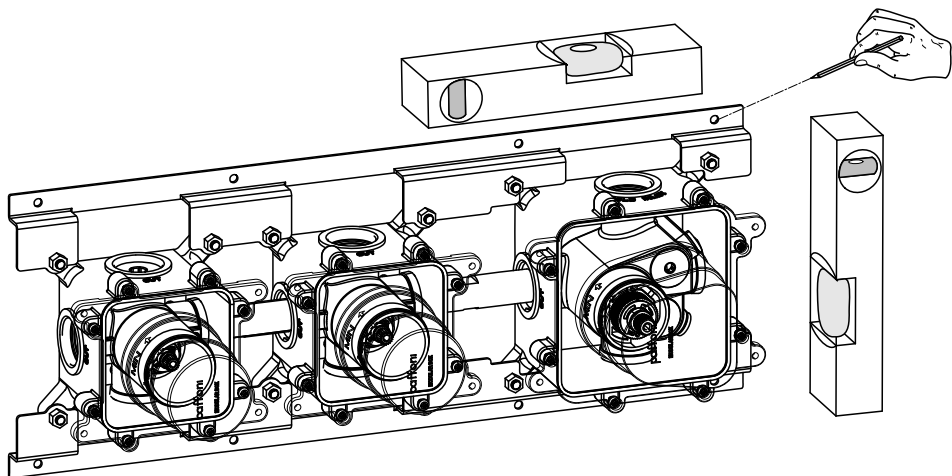
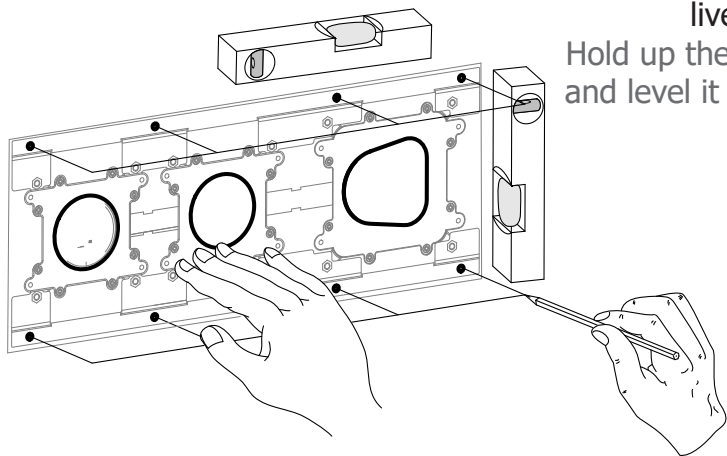

Tipologie di installazione Types of installations

1

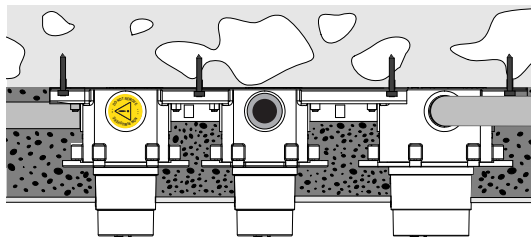

Fissaggio posteriore in
appoggio sul muro
Back fixing resting
on the wall

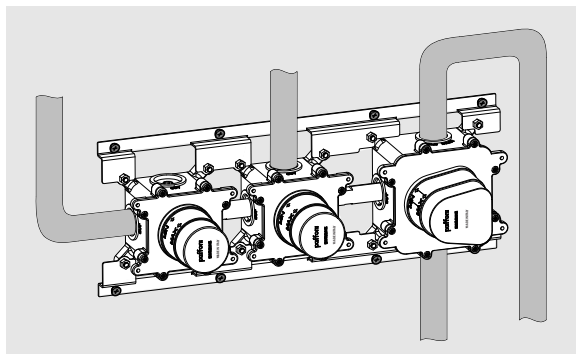

Prima di
completare con i
rivestimenti
eseguire i
**test pressione e
spurgo.**
Before complete
coating make
**Purge and
Pressure test.**
pp.14-15

2

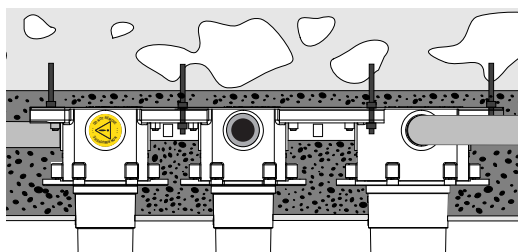

Fissaggio posteriore
sospeso su tasselli
Back fixing hanging
on dowels

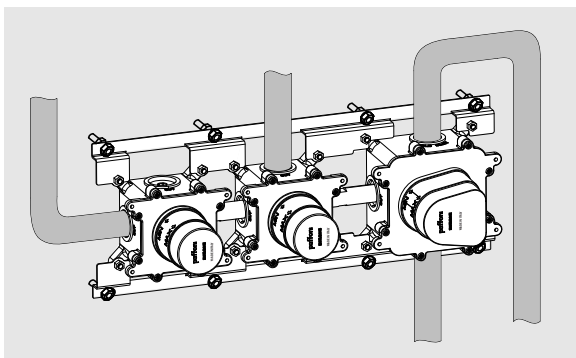

Prima di
completare con i
rivestimenti
eseguire i
**test pressione e
spurgo.**
Before complete
coating make
**Purge and
Pressure test.**
pp.14-15

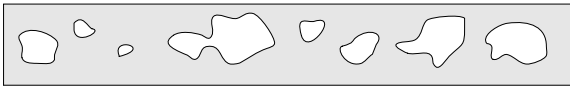

Fissaggio posteriore in
intercapedine

Back fixing in interspace

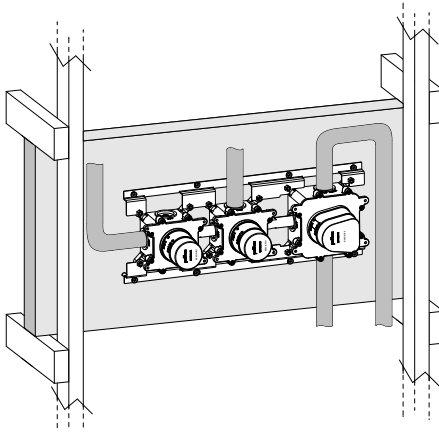
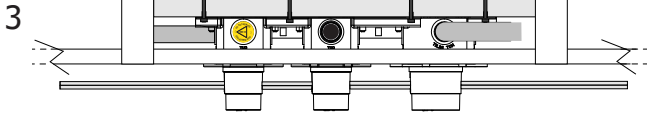

Prima di
completare con i
rivestimenti
eseguire i
**test pressione e
spurgo.**
Before complete
coating make
**Purge and
Pressure test.**
pp.14-15

Spurgo
Purge

a

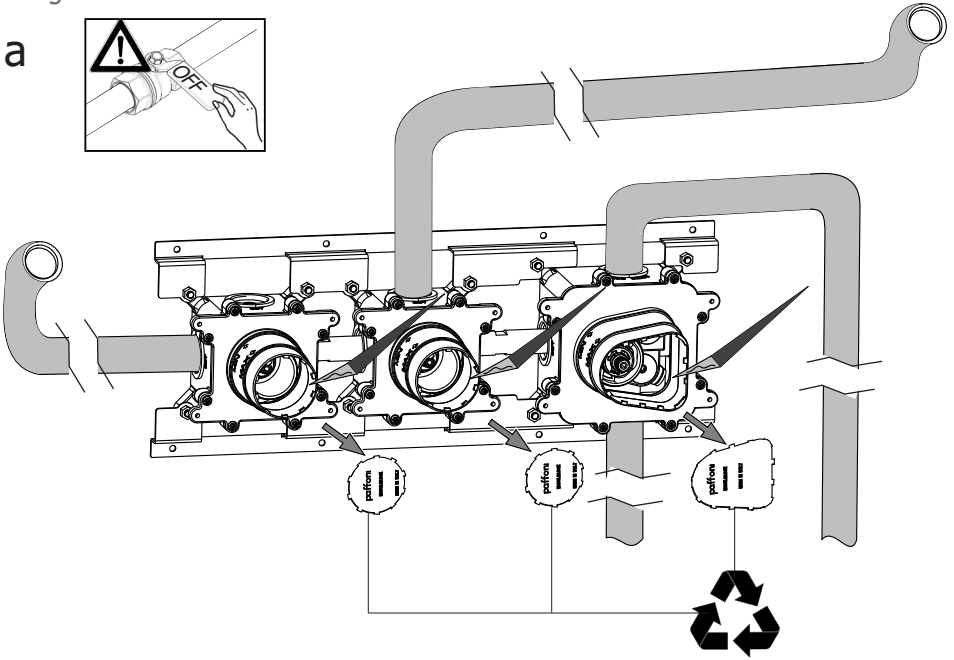
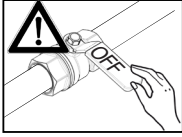

b

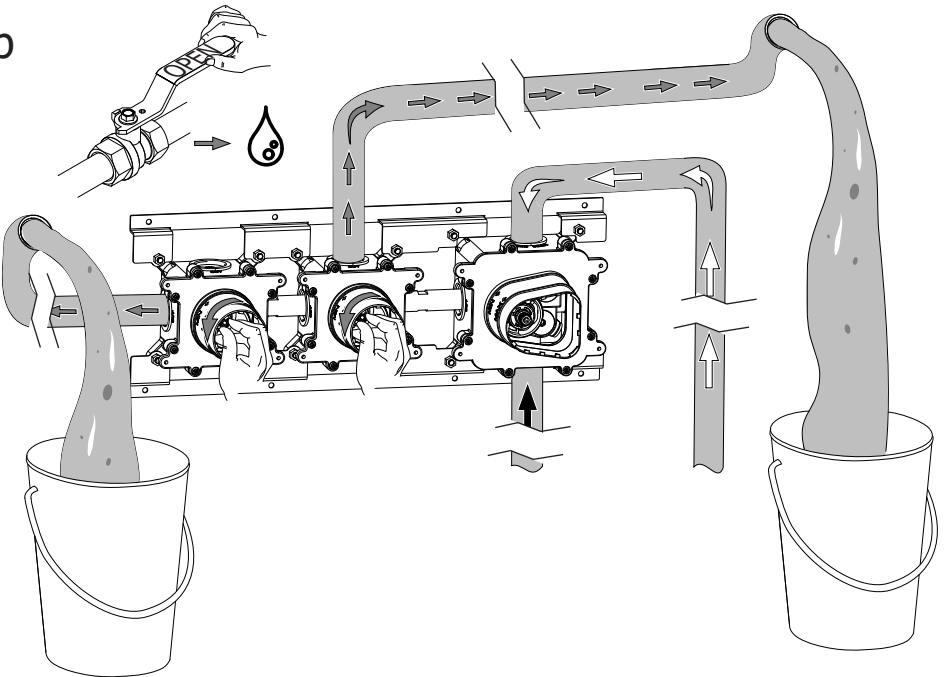

Test perdite e di pressione
Leak and pressure test

a

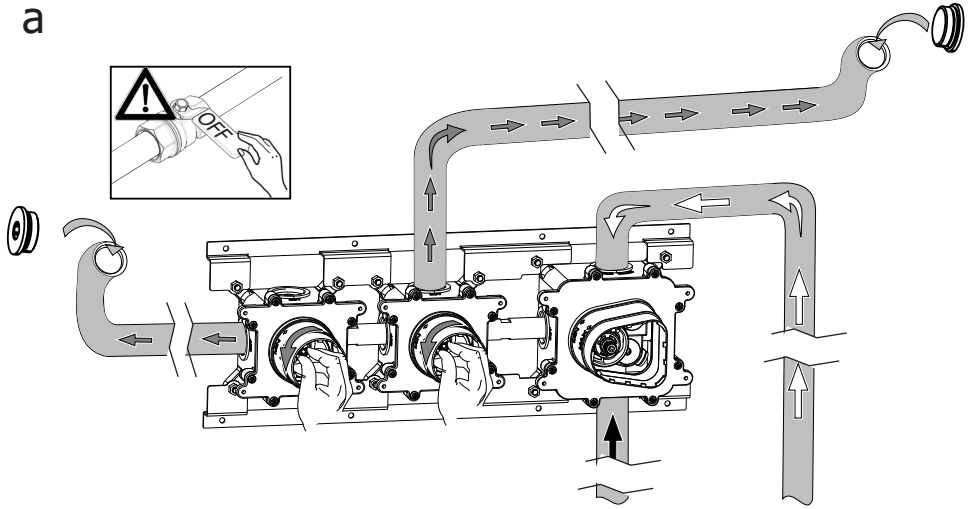

b

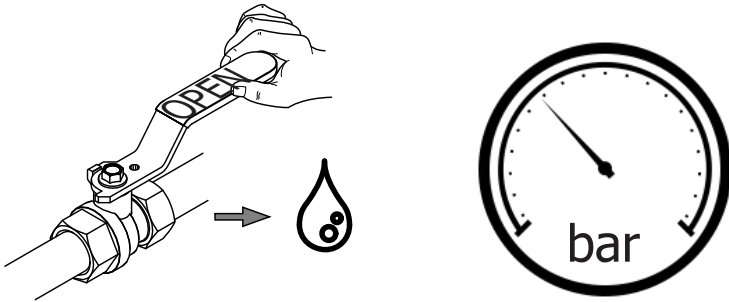

c

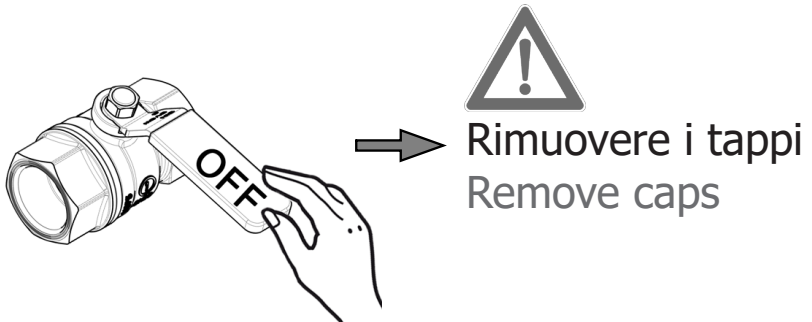

Rifiniture
Finishing touch

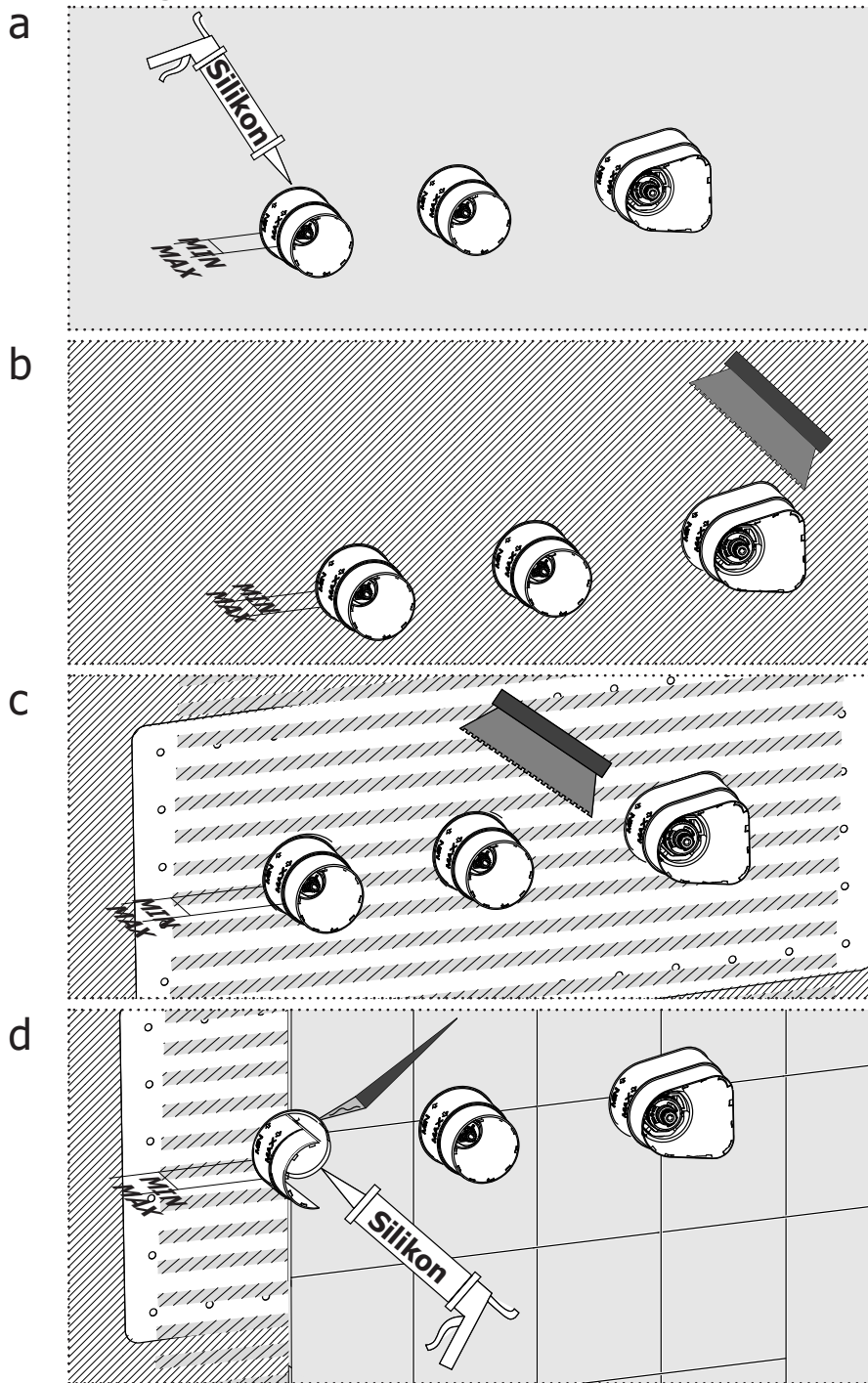

RAPPORTO PROVA DI PORTATA
FLOW RATE REPORT

MDBOX 018

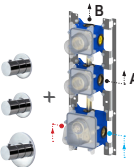
2 Funzioni Functions	Uscita Outlet	Pressione / Pressure (bar)									
		0,5	1,0	1,5	2,0	2,5	3,0	3,5	4,0	4,5	5,0
	A	8,5	12,2	15,2	17,4	19,5	21,3	23,3	25,2	26,9	28,8
	B	8,5	12,2	15,2	17,6	19,6	21,6	23,4	25,1	26,6	28,0
	A + B	10,3	14,8	18,2	21,0	23,4	25,6	27,7	29,7	31,4	33,1

Sostituzione Vitoni ceramici
How to replace Ceramic Disk Valve

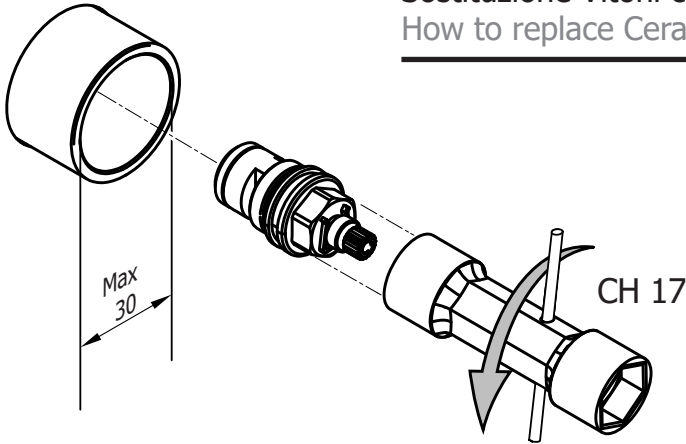

INSTALLAZIONE VERTICALE
VERTICAL INSTALLATION

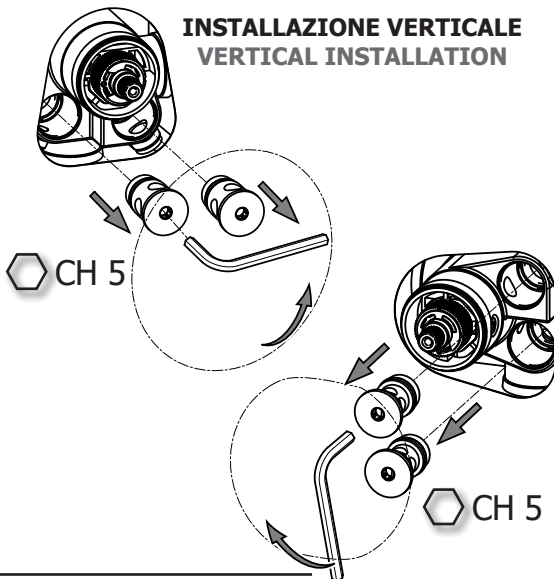

Sostituzione Sede con
Valvolina antiritorno
How to replace Seat with
Check Valve

INSTALLAZIONE ORIZZONTALE
HORIZONTAL INSTALLATION

Sostituzione Cartuccia Termostatica

How to replace Thermostatic Cartridge

INSTALLAZIONE VERTICALE

VERTICAL INSTALLATION

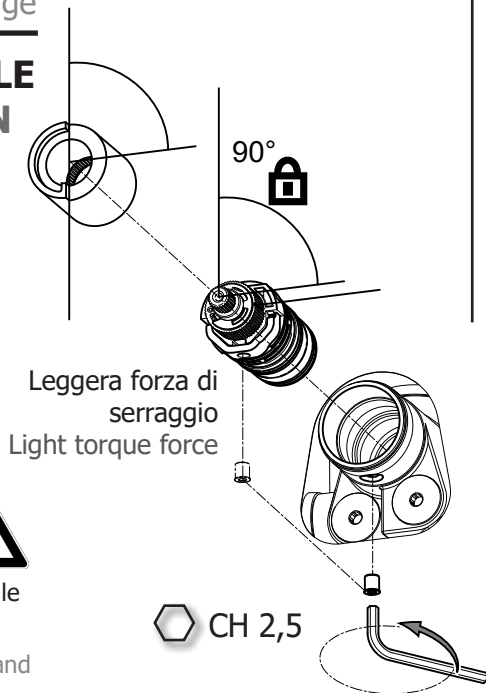

Mantenere sempre 90° tra lo scalino sulla CAM e le linee di riferimento sulla cartuccia

Always keep 90 ° between the step on the CAM and ref. lines on the cartridge

INSTALLAZIONE ORIZZONTALE

HORIZONTAL INSTALLATION

Leggera forza di serraggio
Light torque force

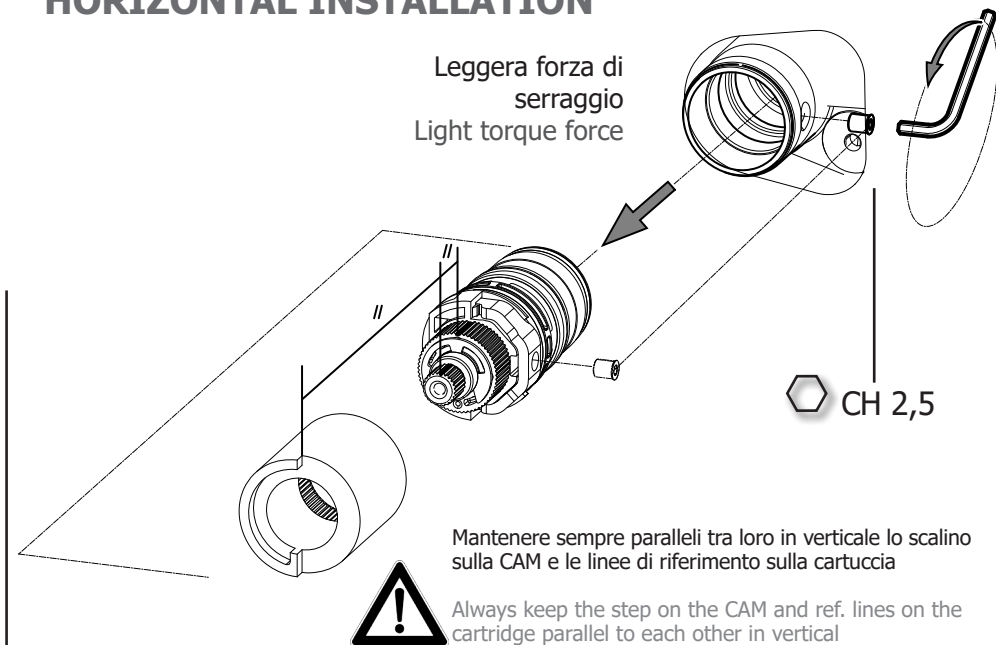

Mantenere sempre paralleli tra loro in verticale lo scalino sulla CAM e le linee di riferimento sulla cartuccia

Always keep the step on the CAM and ref. lines on the cartridge parallel to each other in vertical